



**JARD Trigger System for
CZ 457**

Operators Instruction Manual



3149 Nest Ave. – Sheldon, IA 51201
Phone: 712-324-7409
Email: support@jardinc – www.jardinc.com

WARNING

This firearm is intended for use only by experienced competitive shooters and professionals. You must take responsibility for your own actions. We will not be responsible for any loss, injury, or death resulting from the use or misuse of this product.

The handling and use of firearm bears with a certain unavoidable risks, like sky diving and rock climbing. If you are not willing to accept responsibility for your own actions, guns are not for you.

The use of any custom parts or modifications may void any warranty from the manufacturer of your firearm.

Returns will not be accepted on any parts that have been modified.

If you do not have a thorough understanding of the CZ 457 Trigger Assembly and the purpose and function of all the parts, do not attempt to install this system. Have it installed by an experienced gunsmith.

JARD Trigger System for CZ 457

Installation

1. Verify the gun is unloaded and remove the stock from the receiver.
2. Remove the trigger mounting screw and the mounting pin attaching the trigger housing to the receiver.
3. Remove factory trigger assembly and install the JARD trigger assembly.
4. Install mounting pin followed by the mounting screw and then the stock.

YOUR JARD TRIGGER SYSTEM COMES SET FROM THE FACTORY, NO ADJUSTMENT NEEDED.

If you must make adjustments, follow these instructions carefully. Only adjust the trigger if you fully understand the adjustment process. Adjustments done incorrectly can make your firearm unsafe!

1. Verify the gun is unloaded and remove the stock from the receiver.
2. The sear engagement screw (8A) may now be adjusted. Using a 1/16" hex key, turn the screw counterclockwise several turns and close the bolt leaving the action cocked. Turn the safety selector to the fire position. Slowly turn the screw clockwise until the sear is released (gun fires). Turn the screw slightly back counterclockwise until safe sear engagement is achieved. (Note: There must be sufficient sear engagement to allow reliable safety function, we recommend ½ turn.)
3. Check functioning of the trigger by slamming the bolt (closing it sharply) several times. If the sear is not released when closing sharply, it may be possible to adjust for less sear engagement. However, if the sear is released, more sear engagement and/or pull weight increase is needed.
4. Once the sear engagement has been successfully set, the safety can be adjusted. With the action cocked, turn the safety selector to the safe position. If the safety cannot be engaged, the safety screw (11) must be turned to allow the safety plate to move. Once the safety is on the on position, turn the safety screw with a 1/16" hex key until it engages the safety plate. With the safety is on and the action cocked, there should be no movement in the trigger and the selector should move back and forth freely.
5. To adjust the over-travel screw (8B), cock the action and keep the safety off. Then with a 1/16" hex key, turn the screw clockwise until it contacts the trigger. Pulling the trigger should not release the sear. While pulling on the trigger, slowly turn the screw counterclockwise until the sear is released; it should be turned slightly further to allow for clearance and to avoid binding. If there is not enough clearance, the sear may not always be released when pulling the trigger.
6. The final adjustment can be made to fine tune your trigger pull. The spring tension screw (7A) can be turned in or out with a 5/64" hex key to increase or decrease trigger pull within the posted pull weight ranges.
7. Install the receiver into the stock and perform function and safety checks.

JARD Trigger System for CZ 457 Parts Breakdown List

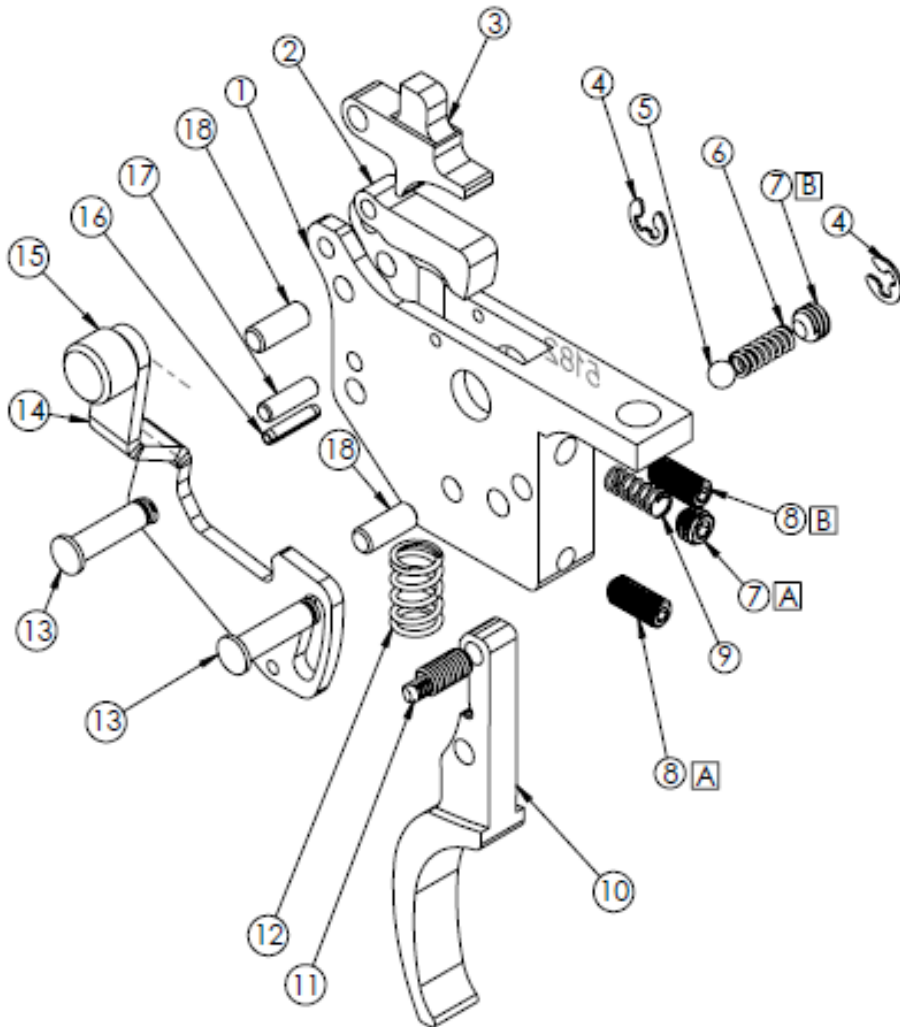

ITEM NO.	PART NO.	DESCRIPTION	QTY.
1	5182	Trigger Housing	1
2	5184	Lower Sear	1
3	2767	Upper Sear	1
4	1254	E-Clip	2
5	1163	.125 Ball	1
6	1061	Spring	1
7	2952	(A) Pull Screw (B) Safety Spring Screw	2
8	1155	Sear Screw (A) Overtravel Screw (B)	2
9	1058 1060 1062	3-6 oz 7-10 oz 11-12 oz	1
10	5183	Trigger	1
11	1444	Safety Screw	1
12	1367	Sear Spring	1
13	1452	Retaining Pin	2
14	5185	Safety	1
15	1231	Safety Knob	1
16	1164	Roll Pin	1
17	1352	Dowel Pin	1
18	3159	Dowel Pin	2

JARD, Inc.

3149 Nest Ave. – Sheldon, IA 51201

Phone: 712-324-7409 – Email: support@jardinc.com

www.jardinc.com